



# **MAXWELL TECHNOLOGIES CAN COMMUNICATION SPECIFICATION**

**Applicable to Maxwell Technologies®  
BOOSTCAP® Energy Storage Modules  
for Heavy Duty Transportation Applications:**

- **BMOD0063 P125      FW 1.33**

## TABLE OF CONTENTS

TABLE OF CONTENTS .....	2
<b>1. DOCUMENT HISTORY .....</b>	<b>4</b>
<b>2. INTRODUCTION .....</b>	<b>5</b>
<b>3. CAN PHYSICAL LAYER.....</b>	<b>5</b>
3.1. BAUD RATE .....	5
3.2. GENERAL CIRCUIT.....	6
3.3. CONNECTOR.....	6
3.4. TERMINATION RESISTORS .....	7
<b>4. CAN IDENTIFIER .....</b>	<b>8</b>
4.1. NODE ID .....	8
4.2. MODULE ID .....	9
4.3. SERVICE ID .....	9
<b>5. CYCLIC MESSAGES .....</b>	<b>9</b>
5.1. CYCLIC MESSAGE 1.....	10
5.1.1. <i>Status 1</i> .....	10
5.1.2. <i>Status 2</i> .....	11
5.1.3. <i>Status 3</i> .....	12
5.1.4. <i>Temperature 1</i> .....	12
5.1.5. <i>Full Voltage</i> .....	13
5.1.6. <i>Half Voltage</i> .....	13
5.2. CYCLIC MESSAGE 2.....	13
5.2.1. <i>5/6<sup>th</sup> Voltage</i> .....	13
5.2.2. <i>2/3<sup>rd</sup> Voltage</i> .....	13
5.2.3. <i>1/3<sup>rd</sup> Voltage</i> .....	14
5.2.4. <i>1/6<sup>th</sup> Voltage</i> .....	14
5.3. CYCLIC MESSAGE 3.....	14
5.3.1. <i>Peak Delta Voltage</i> .....	14
5.3.2. <i>Average Delta Voltage</i> .....	14
<b>6. COMMAND MESSAGES.....</b>	<b>14</b>
6.1. LOADDEFAULT – LOAD FACTORY SETTING .....	15
6.2. GETVERSION – READ VERSION NUMBER.....	15
6.3. GETBOARDSERIALNUMBER - READ THE SERIAL NUMBER OF THE BOARD .....	16
6.4. GETMODULESERIALNUMBER - READ MODULE SERIAL NUMBER.....	16
6.5. SETMASTERNODEID – SET MASTERS NODE ID .....	16
6.6. SETUCMNODEID – SET UCM NODE ID .....	17
6.7. SETMODULEID – SET MODULE ID .....	18
6.8. SETBAUDRATE – SET BAUD RATE .....	18
6.9. SETINTERVAL – SET CYCLIC TRANSMISSION INTERVAL.....	19
6.10. GETINTERVAL – READ CYCLIC TRANSMISSION INTERVAL.....	19
6.11. SETPEAKDELTA LIMIT – SETS THE PEAK DELTA VOLTAGE LIMIT. ....	20
6.12. CALIBRATECHANNEL – CALIBRATES A VOLTAGE CHANNEL.....	20
6.13. ERRORMESSAGE – ERROR MESSAGE.....	21
6.14. RESTART .....	21
<b>7. BOOTLOADER MESSAGES.....</b>	<b>22</b>

7.1.	ENTERBOOTMODE – SWITCH FROM APPLICATION TO BOOTLOADER.....	22
7.2.	ENTERAPPLICATIONMODE – SWITCH FROM BOOTLOADER TO APPLICATION .....	22
7.3.	ERASE – ERASE DATA IN MICRO CONTROLLER FLASH MEMORY .....	23
7.4.	FILL – FILL DATA IN MICRO CONTROLLER TEMPORARY BUFFER.....	23
7.5.	PROGRAM – PROGRAM DATA IN MICRO CONTROLLER FLASH MEMORY .....	23
7.6.	READ – READS DATA FROM MICRO CONTROLLER FLASH MEMORY .....	24
7.7.	READEEPROM – READS DATA FROM MICRO CONTROLLER EEPROM MEMORY .....	24
7.8.	WRITEEEPROM – WRITE DATA IN MICRO CONTROLLER EEPROM MEMORY.....	24
7.9.	CALCULATEFLASHCRC – CALCULATES THE CRC OF THE FLASH MEMORY .....	24
7.10.	PROGRAMFLASHCRC – PROGRAMS THE CRC TO THE FLASH MEMORY .....	25
7.11.	BOOTHEARTBEAT – BOOTLOADER HEART BEAT MESSAGE .....	25
<b>8.</b>	<b>APPENDIX .....</b>	<b>25</b>
8.1.	A LIMIT VALUES .....	25
8.2.	B FACTORY DEFAULT SETTINGS .....	26
8.3.	C STATE DIAGRAM APPLICATION – BOOTLOADER .....	26
8.4.	D BOARD SERIAL NUMBER FORMAT.....	27
8.5.	E MODULE SERIAL NUMBER FORMAT.....	27
8.6.	F VOLTAGE TAPS IN CAPACITOR STRING.....	28
8.7.	G ABBREVIATIONS .....	29

## 1. Document History

Revision	Author	Date	Change	Reason
1.0	USt	2007-07-23	Original	
1.1	USt	2007-07-26	Internal note off	Liberation for customer
	MaxTech	2008-06-24	Match to Code	Cost vs. Functionality
1.2	MSE	2008-10-15	Changes in the communication protocol	Requirement change after telephone conference with customer.
1.21	MSE	2008-11-11	Minor changes	No functional changes.
1.22	MSE	2008-11-26	New Start-up message has been introduced in the protocol, minor changes to SetModuleId command and changed value and function of the Command Time Limit.	Needed new message to be able to recover a unit with an unknown Maste Node ID. The SetModuleID will now be activated immediately and will consequently respond with the new Module ID. The Command Time Limit is now set to 2.4s instead of 30s. No Cyclic Messages will be sent during this time.
1.23	MSE	2008-12-12	Change of value of the Peak Delta Voltage Limit.	The Peak Delta Voltage Limit changed from 2.7VDC to 3.0VDC.
1.24	MSE	2009-01-19	Added new command to change Peak Delta Voltage Limit. Added new command for production calibration.	Added provision for the customer to customize the use of the Peak Delta Flag. Added support command to improve production calibration.
1.31	MSE	2009-02-05	Revision change	Software version changes
1.33	MSE	2009-04-27	Clarification regarding temperature measurement.	It was not clearly specified what happens at the lower and upper limits of the temperature measurements.

## 2. Introduction

This document represents the CAN communication profile for Maxwell Technologies Ultra Capacitor Monitoring unit for 125 VDC Ultra Capacitor Modules.

## 3. CAN Physical Layer

### 3.1. Baud rate

The UCM node supports 125kbit/s, 250kbit/s and 500kbit/s baud rate. The baud rate can be change with a command message specified in chapter 3. The default baud rate is 250kbit/s.

### Bit Timing for CAN controller

The following parameters are specified for operating the CAN controller with the 3 different transfer rates:

Description	125 kbit/s	250 kbit/s	500 kbit/s
Oscillator Frequency	16 MHz	16 MHz	16 MHz
Baud rate Prescaler	7	3	1
Time Quantum (tq)	500 ns	250 ns	125 ns
Synchronization Segment	1 tq	1 tq	1 tq
Propagation Time Segment	7 tq	7 tq	7 tq
Phase Segment 1	4 tq	4 tq	4 tq
Phase Segment 2	4 tq	4 tq	4 tq
Bit Time	$\Sigma 16 \text{ tq} = 8 \mu\text{s}$	$\Sigma 16 \text{ tq} = 4 \mu\text{s}$	$\Sigma 16 \text{ tq} = 2 \mu\text{s}$
Re-Synch Jump Width	1 tq	1 tq	1 tq

### 3.2. General circuit

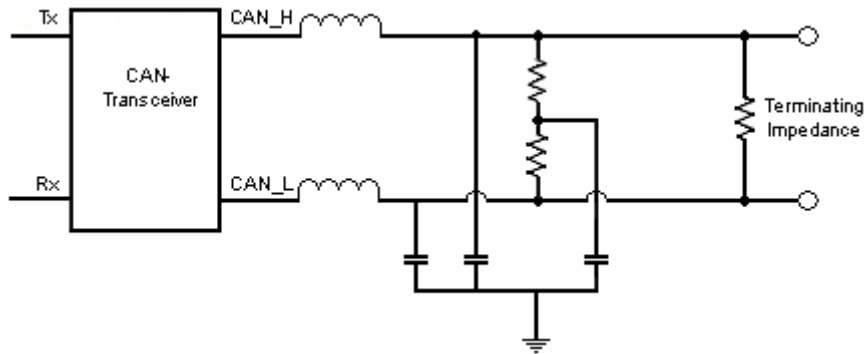

### 3.3. Connector

The HTM125 Ultra Capacitor Module is equipped with two 8 pin Deutsch connectors each on a short cable. One of the connectors is a Socket Plug and one is a Pin Receptacle for easy daisy chaining.

Connector Type	Socket Plug	Pin Receptacle
<b>Drawing Overview</b>		
<b>Connector PN</b>	<b>DTM06-08SA</b>	<b>DTM04-08PA</b>
<b>Wedgelock PN</b>	<b>WM-8S</b>	<b>WM-8D</b>
<b>Socket / Pin PN</b>	<b>0460-202-20141</b>	<b>0462-201-20141</b>

### Connector Pin Out

Description	Pin
<b>CAN_H</b>	<b>1</b>
<b>CAN_L</b>	<b>2</b>
<b>SHIELD</b>	<b>3</b>
<b>NC</b>	<b>4</b>
<b>NC</b>	<b>5</b>
<b>NC</b>	<b>6</b>
<b>24 RTN</b>	<b>7</b>
<b>24 VDC</b>	<b>8</b>

### 3.4. Termination Resistors

The UCM node is not equipped with any internal terminating resistor (Type I ECU). A terminating resistor should be placed at each end of the network main line. Below is an example of network topology with a Type II Master and 6 UCM's.

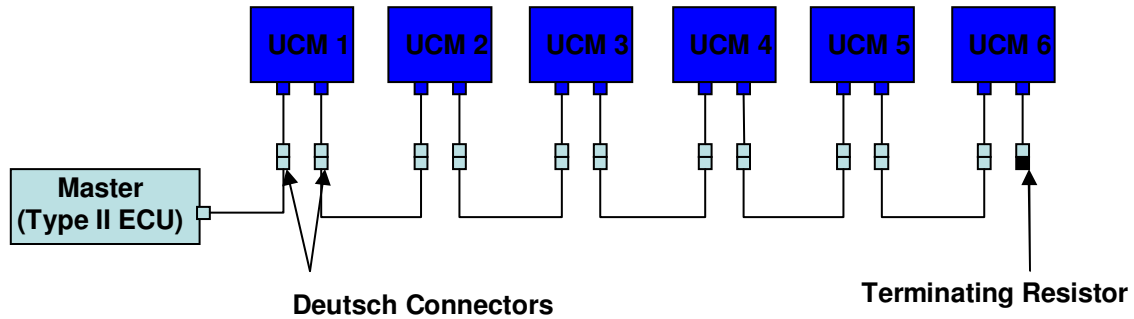



The Node ID is always stored as a 22-bit value in the non-volatile memory. In the case of using the 11-bit CAN identifier format only the 4 least significant bits will be used and the 18 most significant bits will be disregarded.

#### 4.2. Module ID

The Module ID is a unique identifier for each UCM within the network.

Module ID 0 is used by the Master to send a Broadcast message to all nodes. All UCM nodes will acknowledge commands sent with Module Id 0. Note that the Master Node Id still has to match the Master Node Id that the UCM is configured for.

If the Module ID of the UCM is set to 0 the UCM will not respond to any commands but the commands will be executed by the UCM. The only exception to this rule is if the command is a GetSerialNumber command. In that case the UCM responds even though the Module Id is 0.

#### Range:

0x0 – 0xF

#### Default Module ID:

0x0

#### 4.3. Service ID

The Service ID identifies the type of messages send or received by the UCM. The following Service ID's are supported by the UCM:

Description	Service ID	Tx/Rx
<b>Cyclic Message #1</b>	<b>1</b>	<b>Tx</b>
<b>Cyclic Message #2</b>	<b>2</b>	<b>Tx</b>
<b>Cyclic Message #3</b>	<b>3</b>	<b>Tx</b>
<b>Start-up Config Message</b>	<b>4</b>	<b>Tx/Rx</b>
<b>Bootloader Message</b>	<b>6</b>	<b>Tx/Rx</b>
<b>Configuration Message</b>	<b>7</b>	<b>Tx/Rx</b>

Further explanations of the content of these messages are described in individual separate chapters.

## 5. Cyclic Messages

Cyclic CAN messages are sent by the UCM if the Module ID and the Cyclic Transmission Interval Count are both not zero. All Cyclic Messages can be turned on and of independently by means of a bit mask. All activated Cyclic Messages will be sent out evenly distributed over the Cyclic Transmission Interval, i.e. if the Transmission Interval Time is set to 300 ms and all three messages are activated the UCM will send a cyclic message every 100 ms. Both the Cyclic Transmission Interval Count and the Cyclic Message Activation bitmask are configured using the

SetInterval command specified below. The Cyclic Messages will start transmitting when the Command Time Limit following a restart event has run out. The value of the Command Time Limit can be found in Appendix A.

The cyclic messages contain both measured values and status bytes. The Voltage measurement taps are connected to measure between every 8<sup>th</sup> capacitor in the module at the negative terminal. The Full Voltage value is measured between the positive and the negative terminal and the Half Voltage value is measured over the 24 first capacitors. The status bits are derived from a diagnostic procedure which runs every 50ms.

### 5.1. Cyclic Message 1

Description	Value
Service ID	1
Data Length Code (DLC)	8
Cyclic Interval	N x 50 ms*

\* N is the Cyclic Interval Count.

Sender	DB 0	DB 1	DB 2	DB 3	DB 4	DB 5	DB 6	DB 7
UCM	Status 1	Status 2	Status 3	Temp 1	Full Voltage		Half Voltage	

#### 5.1.1. Status 1

##### **Bit 0 Temperature below Low Limit**

This bit is set to 1 if the Temperature is currently below the Low Limit. The value of the low limit is listed in Appendix A (Low Temperature). This indicates a warning that the Temperature is approaching the minimum level which can lead to a serious condition for the Ultra Capacitor Module.

##### **Bit 1 Temperature above High Limit**

This bit is set to 1 if the Temperature is currently over the High Limit. The value of the high limit is listed in Appendix A (High Temperature). This indicates a warning that the Temperature is approaching the maximum level which can lead to a serious condition for the Ultra Capacitor Module.

##### **Bit 2 Full Voltage below Low Limit**

This bit is set to 1 if the Full Voltage is currently below the Low Limit. The value of the low limit is listed in Appendix A (Low Full Voltage).

##### **Bit 3 Full Voltage above High Limit**

This bit is set to 1 if the Full Voltage is currently over the High Limit. The value of the high limit

is listed in Appendix A (High Full Voltage). This indicates a warning that the Voltage is approaching the maximum level which can lead to an over voltage condition for the Ultra Capacitor Cells.

***Bit 4 Peak Delta Has Been Above Maximum Limit***

This bit is set to 1 if the Peak Delta has been over the maximum limit. A definition of the Peak Delta Above Maximum Limit bit can be read below under Status 2, bit 4. The value of the limit is listed in Appendix A (Maximum Peak Delta Voltage). This bit will stay set until it is reset by the restart command (see Command messages).

***Bit 5 Temperature Has Been Above Maximum Limit***

This bit is set to 1 if the Temperature has been over the maximum limit. The value of the maximum limit is listed in Appendix A (Maximum Temperature). This bit will stay set until it is reset by the restart command (see Command messages).

***Bit 6 Full Voltage Has Been Above Maximum Limit***

This bit is set to 1 if the Full Voltage has been over the maximum limit. The value of the maximum limit is listed in Appendix A (Maximum Full Voltage). This bit will stay set until it is reset by the restart command (see Command messages).

***Bit 7 Request Service Has Occurred***

This bit is set to 1 if there has been a request for service on the module. A definition of the request Service bit can be read below under Status 2, Bit 7. This bit will stay set until it is reset by the restart command (see Command messages).

### **5.1.2. Status 2**

***Bit 0 Temperature below Minimum Limit***

This bit is set to 1 if the Temperature is currently below the minimum limit. The value of the minimum limit is listed in Appendix A (Minimum Temperature). It is not recommended to use the Ultra Capacitor Module at this temperature but rather allow the Ultra Cap Module to warm up.

***Bit 1 Half Voltage above Maximum Limit***

This bit is set to 1 if the Half Voltage is currently above the maximum limit. The value of the maximum limit is listed in Appendix A (Maximum Half Voltage). Operating the Ultra Capacitor Module at this voltage may damage the capacitors and lead to a shorter life of the product. It is not recommended to use the Ultra Capacitor Module if this is a lasting or recurring condition.

***Bit 2 Half Voltage below Low Limit***

This bit is set to 1 if the Half Voltage is currently below the Low Limit. The value of the low limit is listed in Appendix A (Low Half Voltage).

***Bit 3 Half Voltage above High Limit***

This bit is set to 1 if the Half Voltage is currently over the High Limit. The value of the high limit is listed in Appendix A (High Half Voltage). This indicates a warning that the Voltage is approaching the maximum level which can lead to a serious condition for the Ultra Capacitor Module.

**Bit 4 Peak Delta above Maximum Limit**

This bit is set to 1 if the Peak Delta is above the Maximum limit. The definition of Peak Delta Voltage is described in chapter 5.3.1. A high value of the Peak Delta indicates an imbalance internally in the Ultra Capacitor Module. The value of the maximum limit is listed in Appendix A (Maximum Peak Delta Voltage). This can be corrected by performing conditioning. It is recommended to do balancing at a higher frequency or not use the Ultra Capacitor Module if this is a recurring condition.

**Bit 5 Temperature above Maximum Limit**

This bit is set to 1 if the Temperature is currently above the maximum limit. The value of the maximum limit is listed in Appendix A (Maximum Temperature). Operating the Ultra Capacitor Module at this temperature may damage the capacitors and lead to a shorter life of the product. It is not recommended to use the Ultra Capacitor Module if this is a lasting or recurring condition.

**Bit 6 Full Voltage above Maximum Limit**

This bit is set to 1 if the Full Voltage is currently above the maximum limit. The value of the maximum limit is listed in Appendix A (Maximum Full Voltage). Operating the Ultra Capacitor Module at this voltage may damage the capacitors and lead to a shorter life of the product. It is not recommended to use the Ultra Capacitor Module if this is a lasting or recurring condition.

**Bit 7 Request Service**

A request for service of the Ultra Capacitor module is currently being made. This request is triggered if the Full Voltage above Maximum, Temperature above Maximum, Half Voltage above Maximum or Temperature below Minimum.

**5.1.3. Status 3**

**Bit 0-7 Not Used**

These bits are reserved for future definition.

**5.1.4. Temperature**

The temperature sensor is placed inside the Ultra Capacitor Module. If the temperature is outside the lower range the unit will report 0 (-40°C). If the temperature is outside the higher range or no sensor is connected the unit will report 255.

Resolution	Range	Units	Offset	Data Type
1 °C/bit	0 to 206 [-40 to 166 °C]	Degree Celsius	-40	uInt08

## Full Voltage

The Full Voltage is measured over all 48 capacitor cells in the module.

Resolution	Range	Units	Offset	Data Type
0.05v/bit	0 to 2800 [0 to 140 VDC]	Volts	0	uInt16

### 5.1.5. Half Voltage

The Half Voltage is measured from the negative terminal over the 24 first capacitor cells.

Resolution	Range	Units	Offset	Data Type
0.05v/bit	0 to 1400 [0 to 70 VDC]	Volts	0	uInt16

## 5.2. Cyclic Message 2

Description	Value
Service ID	2
Data Length Code (DLC)	8
Cyclic Interval	N x 50 ms*

\* N is the Cyclic Interval Count.

Sender	DB 0	DB 1	DB 2	DB 3	DB 4	DB 5	DB 6	DB 7
UCM	5/6 <sup>th</sup> Voltage		2/3 <sup>rd</sup> Voltage		1/3 <sup>rd</sup> Voltage		1/6 <sup>th</sup> Voltage	

### 5.2.1. 5/6<sup>th</sup> Voltage

The 5/6<sup>th</sup> Voltage are measured from the negative terminal over the 40 first capacitor cells.

Resolution	Range	Units	Offset	Data Type
0.05v/bit	0 to 2340 [0 to 117 VDC]	Volts	0	uInt16

### 5.2.2. 2/3<sup>rd</sup> Voltage

The 2/3<sup>rd</sup> Voltage are measured from the negative terminal over the 32 first capacitor cells.

Resolution	Range	Units	Offset	Data Type
0.05v/bit	0 to 1880 [0 to 94 VDC]	Volts	0	uInt16

### 5.2.3. 1/3<sup>rd</sup> Voltage

The 5/6<sup>th</sup> Voltage are measured from the negative terminal over the 16 first capacitor cells.

Resolution	Range	Units	Offset	Data Type
0.05v/bit	0 to 940 [0 to 47 VDC]	Volts	0	uInt16

### 5.2.4. 1/6<sup>th</sup> Voltage

The 1/6<sup>th</sup> Voltage are measured from the negative terminal over the 8 first capacitor cells.

Resolution	Range	Units	Offset	Data Type
0.05v/bit	0 to 480 [0 to 24 VDC]	Volts	0	uInt16

## 5.3. Cyclic Message 3

Description	Value
Service ID	3
Data Length Code (DLC)	8
Cyclic Interval	N x 50 ms*

\* N is the Cyclic Interval Count.

Sender	DB 0	DB 1	DB 2	DB 3	DB 4	DB 5	DB 6	DB 7
UCM	Peak Delta Voltage		Average Delta Voltage		0xFF	0xFF	0xFF	0xFF

#### 5.3.1. Peak Delta Voltage

The definition of Peak Delta is difference between the highest voltage across adjacent voltage taps (see Appendix F) and the lowest value across adjacent voltage taps.

#### 5.3.2. Average Delta Voltage

When calculating the Average Delta Voltage the highest and lowest adjacent tap voltages are ignored. The average is then calculated from the remaining 4 voltages.

## 6. Command Messages

The CAN messages are processed in the UCM only on receipt of a command from its master, after which it acknowledges with a corresponding response. All command messages and command responses are sent with the same Service ID. The command number is transferred in the first data byte (byte 0). The content of data bytes 1-7 are organized specific to the command. The master sends the command to all UCMs (module ID 0) or at one selected UCM (module ID 1-15).

The UCM listens for CAN ID's of the following types:

1. CAN ID from Master with Node ID equal to the one the UCM has been configured for **and** Module ID equal to the one the UCM has been configured for **and** Service Id equal to Configuration Messages.
2. CAN ID from Master with Node ID equal to the one the UCM has been configured for **and** Module ID equal to 0 **and** Service Id equal to Configuration Messages.
3. CAN ID equals to 0x7FC when using Standard CAN format (11-bit identifier) or 0x1FFFFFFC when using extended CAN format (29-bit identifier). This CAN ID will only execute the LoadDefault command. This is used to get started when the CAN configuration settings is unknown. Note that this will always load the default settings on all UCM's that is connected to the network.

The UCM answers only if its configured Module ID is different from 0 unless otherwise stated. (GetSerialNumber shall respond regardless of Module ID).

Unused data bytes are shown as blank for easier reading but should contain 0xFF when composing the CAN message (J-1939's value representing 'not available', see J1939-71:Table1).

### 6.1. LoadDefault – Load factory setting

Description	Sender	DB0	DB1	DB2	DB3	DB4	DB5	DB6	DB7
LoadDefault	Master	0xA5	0x1E	0xEE	0xE1	0xEE	0x1E	0x00	ModuleId
	UCM	0xA5	LsSer#	Ser#2	Ser#3	Ser#4	Ser#5	MsSer#	ModuleId

Parameters can be reset to the factory default values. The factory setting are stored in the program memory and activated after a restart event. The confirmation is sent with the current configured parameters.

This command is ignored if not within the valid Command Time Limit following a restart event. The value of the Command Time Limit can be found in Appendix A.

The following parameters are set to factory default with this command: CAN Format, Master Node ID, UCM Node ID, Module ID, CAN Baud Rate, Cyclic Message Count and Cyclic Message Bit Mask. The default values of these values can be found in Appendix B.

This is a valid broadcast message.

### 6.2. GetVersion – Read version number

Description	Sender	DB0	DB1	DB2	DB3	DB4	DB5	DB6	DB7
GetVersion	Master	0x01							ModuleId
	UCM	0x01	LsHwVer	HwVer2	MsHwVer	LsSwVer (r)	SwVer2 (r)	MsSwVer (V)	ModuleId

Hardware and software version numbers can be read. The lowest bit of the version numbers will be sent first. The Hardware version is sent as 3 bytes with ASCII interpretation. The Software version is sent as 3 bytes with hexadecimal interpretation on the format V.rr where V is a major code version and rr are relatively minor revisions. This is a valid broadcast message.

### 6.3. GetBoardSerialNumber - Read the serial number of the board

Description	Sender	DB0	DB1	DB2	DB3	DB4	DB5	DB6	DB7
GetBoard SerialNum	Master	0x02							ModuleId
	UCM	0x02	LsSer#	Ser#2	Ser#3	Ser#4	Ser#5	MsSer#	ModuleId

The Board Serial Number is 6 bytes of the format described in Appendix D. This number is entered in to the EEPROM when the board goes through the board testing station. This serial number is used as a safe guard key when changing the ModuleId with SetModuleID command. **UCM responds even if its Module ID is zero.** This is a valid broadcast command.

### 6.4. GetModuleSerialNumber - Read module serial number

Description	Sender	DB0	DB1	DB2	DB3	DB4	DB5	DB6	DB7
GetModule SerialNum1	Master	0xB1							ModuleId
	UCM	0xB1	LsSer#0	Ser#1	Ser#2	Ser#3	Ser#4	Ser#5	ModuleId

Description	Sender	DB1	DB2	DB3	DB4	DB5	DB6	DB7	DB8
GetModule SerialNum2	Master	0xB2							ModuleId
	UCM	0xB2	LsSer#6	Ser#7	Ser#8	Ser#9	Ser#10	Ser#11	ModuleId

Description	Sender	DB1	DB2	DB3	DB4	DB5	DB6	DB7	DB8
GetModule SerialNum3	Master	0xB3							ModuleId
	UCM	0xB3	LsSer#12	Ser#13	Ser#14	Ser#15	Ms Ser#16		ModuleId

The Module Serial Number is 17 bytes of the format described in Appendix E. This number is entered in to the EEPROM when the module goes through the module testing station. The Module Serial Number can also be read on a label on the UCM. Note that is the UCM is replaced the Module Serial Number has to be updated to match the label on the module. The spare part UCM's is programmed with all bytes equal to zero. This is a valid broadcast command.

### 6.5. SetMasterNodeID – Set Masters Node ID

Description	Sender	DB0	DB1	DB2	DB3	DB4	DB5	DB6	DB7
SetMasterNode	Master	0x0A	Format	LsNodeId	NodeId2	MsNodeId			ModuleId
	UCM	0x0A	LsSer#	Ser#2	Ser#3	Ser#4	Ser#5	MsSer#	ModuleId

Parameter	Value	Factory Default	Description
Format	0x00	0	11-bit CAN identifier
	0x01 – 0xFF		29-bit CAN identifier
Node ID	0x00 – 0x0F	0x09	11-bit CAN identifier
	0x00000 – 0x3FFFFFF		29-bit CAN identifier

With this command, a new Master Node ID can be assigned to the UCM. The UCM will only recognize and response to messages from the Master with this Node ID. The new Node ID is stored in the UCM non-volatile memory and is activated after a restart event.

The Format parameter is used for switching between the standard CAN format and the extended CAN format. Note that the Format can be changed with both the SetMasterNodeID command and the SetUCMNodeID. The last command sent will override previous commands. The new Format is stored in non-volatile memory and is activated after a restart event.

The command is a valid broadcast message.

## 6.6. SetUCMNodeID – Set UCM Node ID

Description	Sender	DB0	DB1	DB2	DB3	DB4	DB5	DB6	DB7
SetUCMNode	Master	0x0B	Format	LsNodeId	NodeId2	MsNodeId			ModuleId
	UCM	0x0B							ModuleId

Parameter	Value	Factory Default	Description
Format	0x00	0	11-bit CAN identifier
	0x01 – 0xFF		29-bit CAN identifier
Node ID	0x00 – 0x0F	0x0A	11-bit CAN identifier
	0x00000 – 0x3FFFFFF		29-bit CAN identifier

With this command, a new UCM Node ID can be assigned to the UCM. All transmitted messages from the UCM will use this Node ID. The new Node Id is stored in the UCM non-volatile memory and activated only after a restart event. The command is a valid broadcast message.

The Format parameter is used for switching between the standard CAN format and the extended CAN format. Note that the Format can be changed with both the SetMasterNodeID command and the SetUCMNodeID. The last command sent will override previous commands. The new Format is stored in non-volatile memory and is activated after a restart event.

The command is a valid broadcast message.

### 6.7. SetModuleID – Set Module ID

Description	Sender	DB0	DB1	DB2	DB3	DB4	DB5	DB6	DB7
SetModuleId	Master	0x0C	LsSer#	Ser#2	Ser#3	Ser#4	Ser#5	MsSer#	ModuleId
	UCM	0x0C							ModuleId

Parameter	Value	Factory Default
Module ID	0x00 – 0x0F	0

With this command, a new Module ID can be assigned to the UCM. The UCM compares the internally stored serial number with the passed parameter. If the serial numbers match, the new Module ID is stored in its non-volatile memory. The change is activated immediately. The UCM sends the confirmation with the new Module ID. If the serial numbers do NOT match the message will be discarded by the UCM **without** confirmation. Note that the new Module Id is sent in data byte 7.

This command is a valid broadcast message.

### 6.8. SetBaudrate – Set Baud Rate

Description	Sender	DB0	DB1	DB2	DB3	DB4	DB5	DB6	DB7
SetBaudRate	Master	0x0D	LsBitRate	MsBitRate					ModuleId
	UCM	0x0D							ModuleId

Parameter	Value	Factory Default
BaudRate	125, 250 or 500 kbit/s	250 kbit/s

The new Baud Rate is stored in the UCM non-volatile memory and is activated after a restart event.

This command is a valid broadcast message.

## 6.9. SetInterval – Set Cyclic Transmission Interval

Description	Sender	DB0	DB1	DB2	DB3	DB4	DB5	DB6	DB7
SetInterval	Master	0x10	Interval Count	Mask					ModuleId
	UCM	0x10							ModuleId

Parameter	Value	Factory Default
Cyclic Transmission Interval Count	0x00 – 0xFF	0
Cyclic Transmission Mask	0x00 – 0x07	0

With this command, the cyclic transmission interval and cyclic transmission mask of measured data can be changed.

The interval is configured by means of an interval count value. The interval count is a multiplier of 50ms which yields an interval in the area of 0... 12750ms. A multiplier of 0 deactivates the cyclic data transfer.

With the cyclic transmission mask the three cyclic messages can be turned on and of independently. If the bit is set to 1 the messages is activated and if the value is 0 the message is deactivated. The three least significant bits coupled to the cyclic messages according to the following scheme:

- Bit 0 Cyclic Message 1
- Bit 1 Cyclic Message 2
- Bit 2 Cyclic Message 3

All changes take immediate effect. This command is a valid broadcast message.

## 6.10. GetInterval – Read Cyclic Transmission Interval

Description	Sender	DB0	DB1	DB2	DB3	DB4	DB5	DB6	DB7
GetInterval	Master	0x11							ModuleId
	UCM	0x11	IntervalCount	LSB Interval Period	MSB Interval Period	Interval Mask			ModuleId

With this command, the cyclic transmission interval and cyclic transmission mask of measured data can be read.

The interval is configured by means of an interval count value. The interval count is a multiplier of 50ms which yields an interval in the area of 0... 12750ms. A multiplier of 0 deactivates the cyclic data transfer.

With the cyclic transmission mask the three cyclic messages can be turned on and of

independently. If the bit is set to 1 the messages is activated and if the value is 0 the message is deactivated. The three least significant bits coupled to the cyclic messages according to the following scheme:

- Bit 0 Cyclic Message 1
- Bit 1 Cyclic Message 2
- Bit 2 Cyclic Message 3

This command is a valid broadcast message.

### 6.11. SetPeakDeltaLimit – Sets the Peak Delta Voltage Limit.

Description	Sender	DB0	DB1	DB2	DB3	DB4	DB5	DB6	DB7
SetPeakDeltaLimit	Master	0x14	LsVoltLimit	MsVoltLimit					ModuleId
	UCM	0x14							ModuleId

With this command, the Peak Delta Voltage Limit can be changed. If the Peak Delta Voltage gets over this limit the Peak Delta Voltage Flag will be set. The resolution of this value is 0.05v/bit. This limit can be set to any value between 0 and 200 [0 VDC and 10 VDC].

This command is a valid broadcast message.

### 6.12. CalibrateChannel – Calibrates a Voltage Channel

Description	Sender	DB0	DB1	DB2	DB3	DB4	DB5	DB6	DB7
CalibrateChannel	Master	0x20	ChannelNr	LsCalibV	MsCalibV	Key 1	Key 2	Key 3	ModuleId
	UCM	0x20							ModuleId

This command is used in the calibration process when these modules are produced. This command is not intended for customer use.

The ChannelNr corresponds to the voltage tap requested to be calibrated:

- 0 = 48<sup>th</sup> cell tap
- 1 = 40<sup>th</sup> cell tap
- 2 = 32<sup>nd</sup> cell tap
- 3 = 24<sup>th</sup> cell tap
- 4 = 16<sup>th</sup> cell tap
- 5 = 8<sup>th</sup> cell tap

The CalibV corresponds to the calibration voltage set at the tap input. The resolution of this value is 0.01/bit.

This command is a valid broadcast message.

### 6.13. ErrorMessage – Error Message

Description	Sender	DB0	DB1	DB2	DB3	DB4	DB5	DB6	DB7
ErrorMessage	UCM	0xEE	Source	Code					ModuleId

In case of an error, the UCM sends an Error Message. The source of the error is reported in data byte 2 and the error cause is reported in data byte 3. An error message could be sent instead of a response to a command if the command failed. Then the error source will correspond to the command number. The error message could also be sent when an internal error is detected. Then the definition of the error source will depend on the type of error that has occurred. So far only errors triggered by commands are implemented.

Error code:

- 1: Invalid command format (invalid DLC, wrong data bytes numbers)
- 2: Not implemented command (interpretation of data byte 1 not implemented)
- 3: Invalid parameter value
- 4: Program validation failure
- 5: EeData validation failure
- 6: Command failed

### 6.14. Restart

Description	Sender	DB0	DB1	DB2	DB3	DB4	DB5	DB6	DB7
Restart	Master	0xA0	0x1E	0xEE	0xE1	0xEE	0x1E	Restart Alt.	ModuleId
	UCM	0xA0	LsSer#	Ser#2	Ser#3	Ser#4	Ser#5	MsSer#	ModuleId

During normal operation it may be necessary to restart a module (such as after certain set commands or to allow special set commands). There are two types of restarts available, the warm boot and the cold boot. This command can also be used to reset the latching status bits in Status Byte 1 in Cyclic Message 1. The different alternatives are commanded as follows:

Restart Alternative Bit Flag	Description
0	Warm Boot
1	Reserved
2	Reserved
3	Reset Latching Flags
4	Reserved
5	Reserved
6	Reserved
7	Cold Boot

The warm boot will restart the execution in the firmware application and the execution will



not go through the bootloader (see Appendix C). This restart is generally used to activate changes that are stored in EEPROM.

The cold boot will restart the execution in the bootloader and then depending on flags in EEPROM jump to start execute in the firmware application.

See chapter 5.1 for a description of the latching status bits.

This is a valid broadcast message.

## 7. Bootloader Messages

The Ultra Cap Monitor includes an embedded Bootloader that allows the units Application firmware to be programmable over the CAN bus. The Bootloader also facilitates a way of writing directly into the EEPROM as well as the Flash memory. It is not recommended that this is done by the end user. Note that all of the bootloader messages used in Bootloader mode have 7 byte data length.

The EnterBootMode command is the only Bootloader command that is recognized by the Application. All other messages are only recognized by the Bootloader. See Appendix C for an overview of how the switch between the different modes is performed.

### EnterBootMode – switch from Application to Bootloader

Description	Sender	DB0	DB1	DB2	DB3	DB4	DB5	DB6	DB7
EnterBootMode	Master	0xE0	LsSer#	Ser#2	Ser#3	Ser#4	Ser#5	MsSer#	ModuleId
	UCM	0xE0	LsSer#	Ser#2	Ser#3	Ser#4	Ser#5	MsSer#	ModuleId

With this command the Ultra Cap Monitor will switch from executing the Application firmware to executing the Bootloader firmware. This command is only recognized if received within 30s from a restart event. The response is sent out before the switch takes place and should not be seen as a confirmation of a successful command. Look for the Bootloader heart beat message specified below for verification of that the UCM is in Boot mode. Use the EnterApplicationMode command specified below to switch back to the Application mode.

### 7.1. EnterApplicationMode – switch from Bootloader to Application

Description	Sender	DB0	DB1	DB2	DB3	DB4	DB5	DB6
EnterApplicationMode	Master	0xE5						
	UCM	0xE5						

With this command the Ultra Cap Monitor will switch from executing the Bootloader firmware to

executing the Application firmware. The response is sent out before the switch takes place and should not be seen as a confirmation of a successful command. Send a GetSerialNumber command to verify that the command was successful. Use the EnterBootMode command specified below to switch back to the Boot mode.

### 7.2. Erase – Erase data in Micro Controller flash memory

Description	Sender	DB0	DB1	DB2	DB3	DB4	DB5	DB6
Erase	Master	0xE1	Ls Address	Address 2	Address 3	Ms Address		
	UCM	0xE1						

This command is used when the Ultra Cap Monitor is programmed with new firmware. It is not recommended that this command is used by anything else but approved programming tools. Failure to follow this recommendation could bring the Ultra Cap Monitor to an unrecoverable failure state.

### Fill – Fill data in Micro Controller temporary buffer

Description	Sender	DB0	DB1	DB2	DB3	DB4	DB5	DB6
Fill	Master	0xE2	Ls Address	Address 2	Address 3	Ms Address	Ls Data	Ms Data
	UCM	0xE2						

This command is used when the Ultra Cap Monitor is programmed with new firmware. It is not recommended that this command is used by anything else but approved programming tools. Failure to follow this recommendation could bring the Ultra Cap Monitor to an unrecoverable failure state.

### 7.3. Program – Program data in Micro Controller flash memory

Description	Sender	DB0	DB1	DB2	DB3	DB4	DB5	DB6
Program	Master	0xE3	Ls Address	Address 2	Address 3	Ms Address		
	UCM	0xE3						

This command is used when the Ultra Cap Monitor is programmed with new firmware. It is not recommended that this command is used by anything else but approved programming tools. Failure to follow this recommendation could bring the Ultra Cap Monitor to an unrecoverable failure state.

#### 7.4. Read – Reads data from Micro Controller flash memory

Description	Sender	DB0	DB1	DB2	DB3	DB4	DB5	DB6
Read	Master	0xE4	Ls Address	Address 2	Address 3	Ms Address		
	UCM	0xE4	Ls Data Byte	Data Byte 2	Data Byte 3	Data Byte 4	Data Byte 5	Data Byte 6

This command is used to read the data from the flash memory of the Ultra Cap Monitor

#### 7.5. ReadEEPROM – Reads data from Micro Controller EEPROM memory

Description	Sender	DB0	DB1	DB2	DB3	DB4	DB5	DB6
ReadEEPROM	Master	0xE6	Ls Address	Ms Address				
	UCM	0xE6	Data Byte					

This command is used to read the data from the EEPROM memory of the Ultra Cap Monitor.

#### 7.6. WriteEEPROM – Write data in Micro Controller EEPROM memory

Description	Sender	DB0	DB1	DB2	DB3	DB4	DB5	DB6
WriteEEPROM	Master	0xE7	Ls Address	Ms Address	Data Byte			
	UCM	0xE7						

This command is used to read the data from the EEPROM memory of the Ultra Cap Monitor. It is not recommended that this command is used by anything else but approved programming tools. Failure to follow this recommendation could bring the Ultra Cap Monitor to an unrecoverable failure state.

#### 7.7. CalculateFlashCRC – Calculates the CRC of the Flash memory

Description	Sender	DB0	DB1	DB2	DB3	DB4	DB5	DB6
CalculateFlashCRC	Master	0xE8						
	UCM	0xE8	Ls CRC	Ms CRC				

This command is used to calculate the Cyclic Redundancy Checksum when the Ultra Cap Monitor is programmed with new firmware.

## 7.8. ProgramFlashCRC – Programs the CRC to the Flash memory

Description	Sender	DB0	DB1	DB2	DB3	DB4	DB5	DB6
CalculateFlashCRC	Master	0xE9						
	UCM	0xE9	LS CRC	MS CRC				

This command is used when the Ultra Cap Monitor is programmed with new firmware. It is not recommended that this command is used by anything else but approved programming tools. Failure to follow this recommendation could bring the Ultra Cap Monitor to an unrecoverable failure state.

## BootHeartBeat – Bootloader Heart Beat message

Description	Sender	DB0	DB1
BootHeartBeat	UCM	0xEA	Config Cks

When the UCM is in the boot mode it will send out a heart beat message with 1 Hz frequency. This message contains the checksum of the configuration parameters currently in use. This message can be used to verify that the UCM is currently executing the bootloader firmware and are now responding to messages specified in this section of the specification.

## 8. Appendix

### 8.1. A Limit values

Description	Value	Unit
Maximum Full Voltage	134.0	Volts
High Full Voltage	126.6	Volts
Low Full Voltage	30.0	Volts
Minimum Full Voltage	10.0	Volts
Maximum Half Voltage	67.0	Volts
High Half Voltage	63.3	Volts
Low Half Voltage	5.0	Volts
Maximum Temperature	65	°C
High Temperature	55	°C
Low Temperature	-30	°C
Minimum Temperature	-40	°C
Maximum Peak Delta Voltage	6.0	Volts
Command Time Limit	2.0	Sec

### 8.2. B Factory Default Settings

Description	Value
Board Serial Number	Uniquely assigned during manufacturing. See Appendix D.
Hardware version	Assigned during manufacturing.
Software version	Unique to code and stored in flash memory.
CAN Message Format	Standard 11 bit CAN ID. [0]
Master Node ID	9d, 1001b
UCM Node ID	10d, 1010b
Module ID	0
Baud Rate	250 kbit/s
Cyclic Message Count	0 (sending deactivated)
Cyclic Message Bit Mask	0 (all three messages deactivated)
Module Serial Number	All 0 as default for separate board. Uniquely assigned during manufacturing if the board is mounted in a module. See Appendix E.

### 8.3. C State Diagram Application – Bootloader

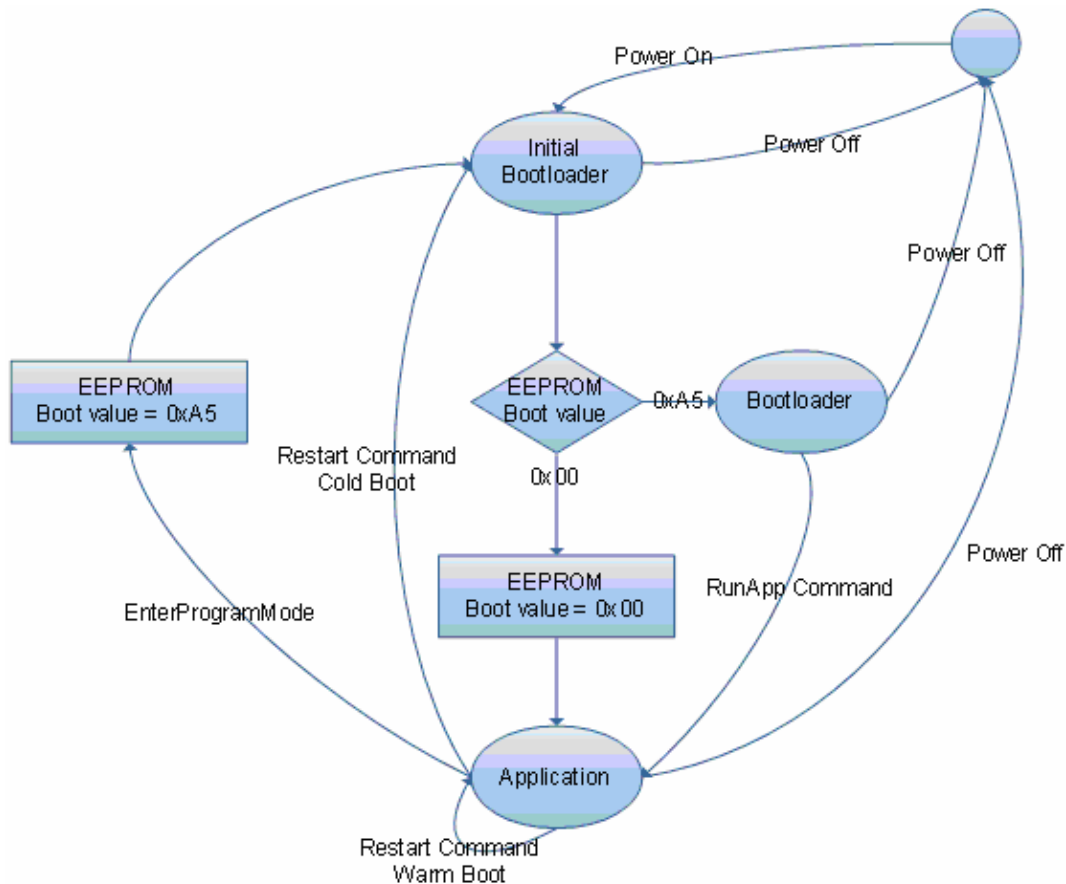

#### 8.4. D Board Serial Number Format

DB0	DB1	DB2	DB3	DB4	DB5
P	D	D	L	#	#

Symbol	Description	Value	Interpretation	Type
P	Product Type	1	CAN Monitor	Dec
DD	Date	08286	Year + Julian Date (New Style)	Dec
L	Location	D	San Diego	ASCII
##	Day serial number	0	0 – 65535	Dec

#### 8.5. E Module Serial Number Format

DB0	DB1	DB2	DB3	DB4	DB5	DB6	DB7	DB8	DB9
M	V	V	V	C	C	P	Y	Y	D

DB10	DB11	DB12	DB13	DB14	DB15	DB16
D	D	L	#	#	#	#

Symbol	Description	Value	Interpretation	Type
M	Module / Pack	M	Always M	ASCII
VVV	Product Voltage	125	125VDC	ASCII
CC	Cell capacitance	30	3000F	ASCII
P	Product Type	P	Power/Active Balancing	ASCII
YY	Year	08	2008	ASCII
DDD	Day	360	1-366 Julian Date (New Style)	ASCII
L	Location	D	San Diego	ASCII
####	Serial Number	23	0-9999	ASCII

### 8.6. F Voltage Taps in Capacitor String

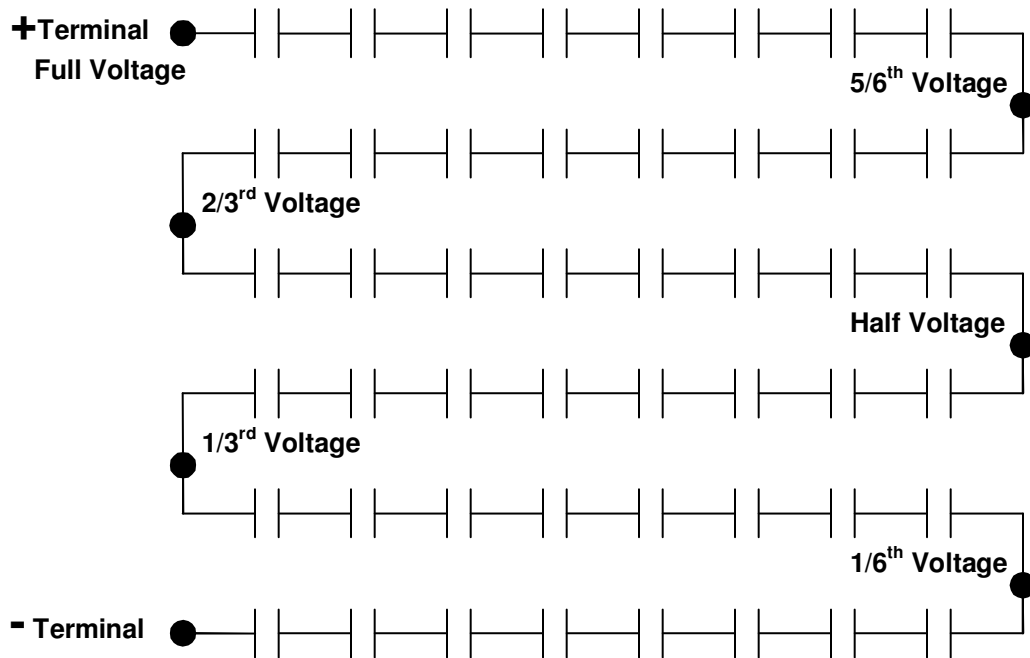

## 8.7. G Abbreviations

BCD	Binary Coded Decimal
CAN	Controller Area Network
DLC	Data Length Code
ID	Identifier
LSB	Least Significant Bit or Byte
MSB	Most Significant Bit or Byte
UCM	UltraCap Module
TBD	To be determined
UC	Unsigned char, 8 bit
US	Unsigned short, 16 bit
DB	Data byte

**Maxwell Technologies, Inc.**  
**Worldwide Headquarters**  
 9244 Balboa Avenue  
 San Diego, CA 92123  
 USA  
 Phone: +1 858 503 3300  
 Fax: +1 858 503 3301

**Maxwell Technologies SA**  
 CH-1728 Rossens  
 Switzerland  
 Phone: +41 (0)26 411 85 00  
 Fax: +41 (0)26 411 85 05

**Maxwell Technologies GmbH**  
 Brucker Strasse 21  
 D-82205 Gilching  
 Germany  
 Phone: +49 (0)8105 24 16 10  
 Fax: +49 (0)8105 24 16 19

**Maxwell Technologies, Inc. -**  
**Shanghai Representative Office**  
 Rm.2104, Suncome Liauw's Plaza  
 738 Shang Cheng Road  
 Pudong New Area  
 Shanghai 200120, P.R. China  
 Phone: +86 21 5836 5733  
 Fax: +86 21 5836 5620